

# SHOP PROP SERIES

## SUBMITTAL DATA - HVLS CEILING FANS & ACCESSORIES

SUBMITTED BY: \_\_\_\_\_ DATE: \_\_\_\_\_

JOB TITLE: \_\_\_\_\_ CONTRACTOR: \_\_\_\_\_

ADDRESS: \_\_\_\_\_ PHONE #: \_\_\_\_\_

CITY: \_\_\_\_\_ ADDRESS: \_\_\_\_\_

STATE: \_\_\_\_\_ ZIP: \_\_\_\_\_ CITY: \_\_\_\_\_

STATE: \_\_\_\_\_ ZIP: \_\_\_\_\_

ENGINEER: \_\_\_\_\_

LOCAL REPRESENTATIVE: \_\_\_\_\_

QTY.	MODEL #	FAN DIAMETER	VOLTAGE RANGE <sup>1</sup>	MOTOR FLA	PHASE	HP	AREA COVERED	MAX EFFECTIVE DIAMETER <sup>2</sup>	MAX SPEED	INSTALLED WEIGHT
	SP-0618-512-1	6 Ft. (1.8 m)	110-115 VAC	5.2	1	1.35 HP (1.0 kW)	2,826 Ft <sup>2</sup> (262 m <sup>2</sup> )	60 Ft. (18 m)	170 RPM	101 lb (46 kg)
	SP-0618-523-1		200-240 VAC		1					
	SP-0618-523-3		220-240 VAC		3					
	SP-0618-546-3		400-480 VAC		3					
	SP-0824-512-1	8 Ft. (2.4 m)	110-115 VAC	5.2	1	1.35 HP (1.0 kW)	5,024 Ft <sup>2</sup> (467m <sup>2</sup> )	80 Ft. (24 m)	130 RPM	105 lb (48 kg)
	SP-0824-523-1		200-240 VAC		1					
	SP-0824-523-3		220-240 VAC		3					
	SP-0824-546-3		400-480 VAC		3					
	SP-1030-512-1	10 Ft. (3.0 m)	110-115 VAC	5.2	1	1.35 HP (1.0 kW)	7,850 Ft <sup>2</sup> (730 m <sup>2</sup> )	100 Ft. (30 m)	85 RPM	110 lb (50 kg)
	SP-1030-523-1		200-240 VAC		1					
	SP-1030-523-3		220-240 VAC		3					
	SP-1030-546-3		400-480 VAC		3					
	SP-1236-512-1	12 Ft. (3.6 m)	110-115 VAC	5.2	1	1.35 HP (1.0 kW)	11,304 Ft <sup>2</sup> (1,050 m <sup>2</sup> )	120 Ft. (36 m)	80 RPM	114 lb (52 kg)
	SP-1236-523-1		200-240 VAC		1					
	SP-1236-523-3		220-240 VAC		3					
	SP-1236-546-3		400-480 VAC		3					
	SP-1443-512-1	14 Ft. (4.3 m)	110-115 VAC	5.2	1	1.35 HP (1.0 kW)	15,386 Ft <sup>2</sup> (1,429m <sup>2</sup> )	140 Ft. (43 m)	60 RPM	118 lb (54 kg)
	SP-1443-523-1		200-240 VAC		1					
	SP-1443-523-3		220-240 VAC		3					
	SP-1443-546-3		400-480 VAC		3					
	SP-1649-512-1	16 Ft. (4.9m)	110-115 VAC	5.2	1	1.35 HP (1.0 kW)	20,096 Ft <sup>2</sup> (1,867 m <sup>2</sup> )	160 Ft. (49 m)	45 RPM	122 lb (56 kg)
	SP-1649-523-1		200-240 VAC		1					
	SP-1649-523-3		220-240 VAC		3					
	SP-1649-546-3		400-480 VAC		3					

<sup>1</sup> 277v Power source is not accepted. <sup>2</sup> Estimated values based on typical conditions.



Rated voltage for the appliance is 460V. Steady voltages in the high 490's and spikes above this can damage the onboard electronics.



# SHOP PROP SPECIFICATIONS

## BLADES

- Equipped with 5 blades
- Extruded anodized aluminum
- High performance E420 design with STOL technology

## CONSTRUCTION

- Mounting is to be 1/4" powder-coated steel and anodized aluminum
- All construction is to be protected from the elements
- Stainless steel safety brackets

## VFD

- Onboard, IP65 rating
- Factory assembled & programmed
- Minimum start/stop torque loads

## WINGTIPS

- Equipped with 5 wingtips
- Constructed of nylon 66
- Redirect outward airflow into downward airflow

## MOTOR

- Direct drive ECM motor
- Totally enclosed
- IP65 rating
- Class F insulation
- 1.35HP (1.0 kW) nominal horsepower

## STANDARD LIMITED WARRANTY

- 5 year: Motor
- 1 year: Electronics
- Lifetime: Blade
- Extended warranties available

# SHOP PROP SERIES SAFETY CLEARANCES & DROP HEIGHT<sup>1</sup>

MODEL #	DIAMETER	SIDE	ABOVE	BELOW	MIN. BLADE HEIGHT	BLADE DROP HEIGHT
SP-0618	6 Ft (1.8 m)	11"	20"	11"	10'	22.25"
SP-0824	8 Ft (2.4 m)	15"	20"	15"	10'	22.25"
SP-1030	10 Ft (3.0 m)	18"	20"	18"	10'	22.25"
SP-1236	12 Ft (3.6 m)	22"	20"	22"	10'	22.25"
SP-1443	14 Ft (4.3 m)	26"	20"	26"	10'	22.25"
SP-1649	16 Ft (4.9 m)	29"	20"	29"	10'	22.25"

<sup>1</sup> All dimensions are based on a standard 6-1/2" extension bar.

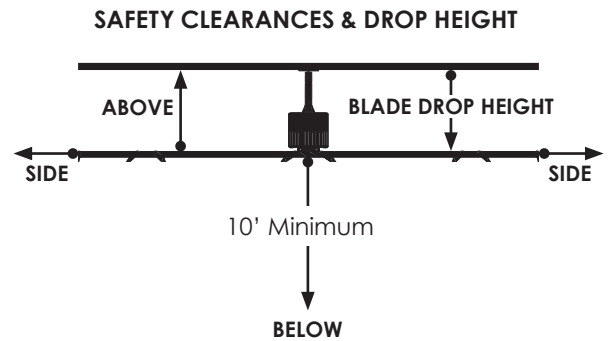

# SHOP PROP SERIES MAX EFFECTIVE DIAMETER

DISTANCE FROM CENTER	AIR VELOCITY <sup>2</sup>	COOLING SENSATION <sup>2</sup>
0' - 40' (0-12.2m)	620 - 900 fpm 3 - 4.5 m/s	8 - 15°F 5 - 10°C
41' - 70' (12.3-21.3m)	340 - 620 fpm 1.7 - 3 m/s	0 - 8°F 0 - 5°C

<sup>2</sup> Stated values are estimations based on standard installation at maximum power. Values such as building layout, obstructions, ceiling height, and drop ceiling height may effect these numbers.

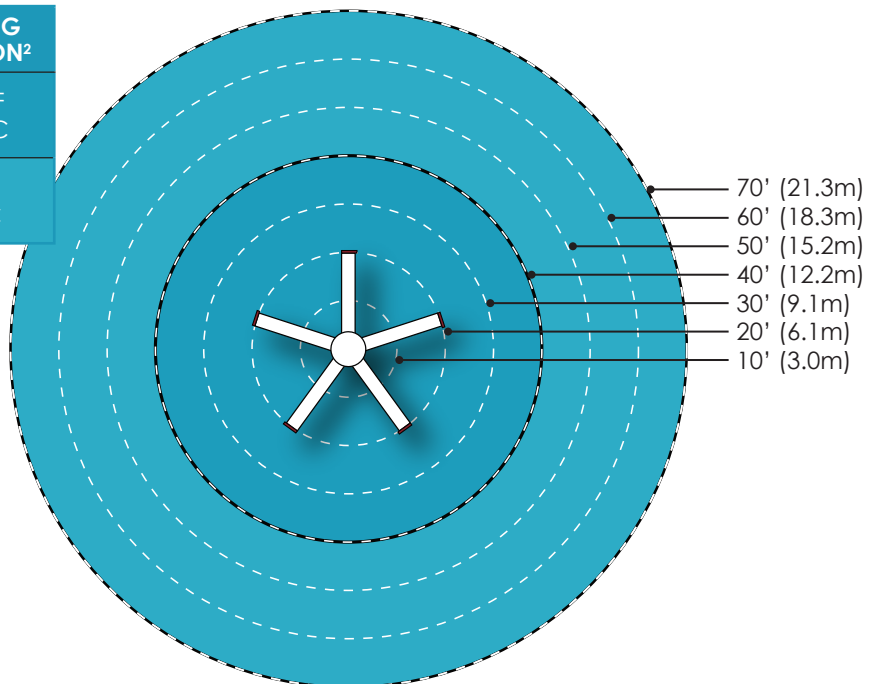

# SHOP PROP SERIES INSTALLATION

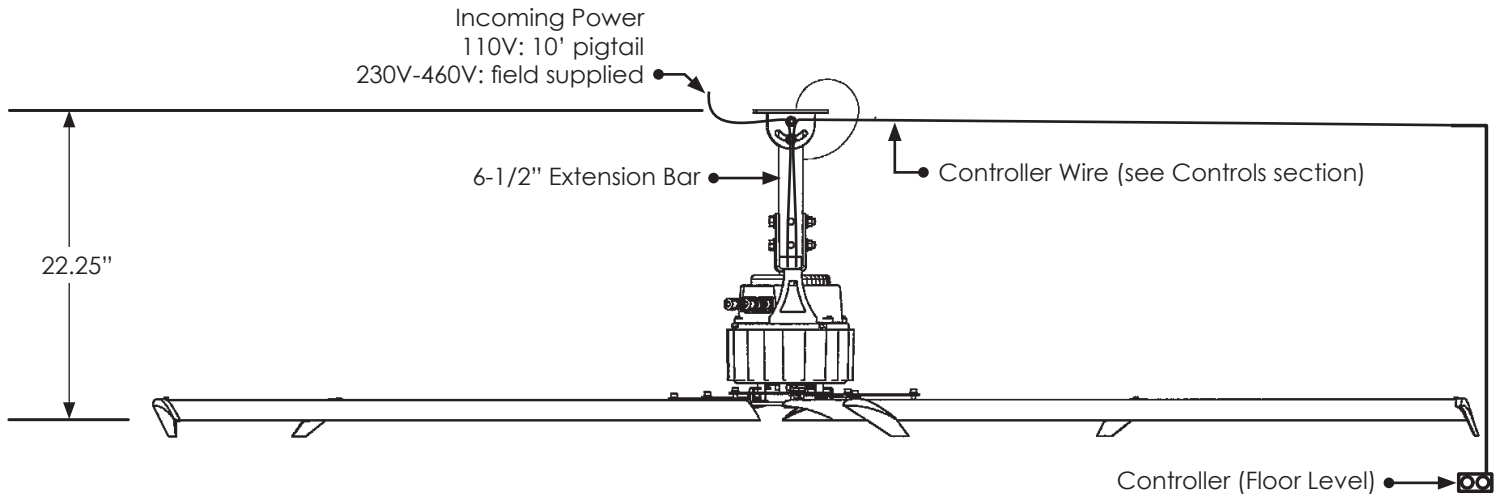

## SHOP PROP SERIES OPTIONAL ACCESSORIES & UPGRADES

QTY.	PART #	DESCRIPTION	NOTES
<b>EXTENSION BARS</b>			
	1002-X	Extension Bar	Lowers assembly in 1 ft increments. All models come standard with a 6-1/2" extension. Custom lengths up to 5-ft. are available.
QTY.	6-1/2"	1'	2' 3' 4' 5'
<b>CONTROLLER TYPES</b>			
	DP-767.10	Ground Control	Wall mounted control for BACnet & BMS integration. Control multiple fans in groups or individually. Standard offering controls up to 2 fans. Expandable up to 50 fans. Contact factory for expanded options.
	BP-769.XX	7" AutoPilot 2.0 Controller	7" touchscreen controller supports multiple fans as a stand alone controller or through bacnet & BMS integration. Schedule start & stop run times [XX] = 1-10 fans [10], 1-25 fans [25], 1-35 fans [35].
	BP-770.XX	10" AutoPilot 2.0 Controller	10" touchscreen controller with temperature control module upgrade. Supports multiple fans as a stand alone controller or through BACnet & BMS integration. Schedule start & stop run times. Includes upgraded module with two (2) temperature probes per controller to allow for automatic summer & winter mode programs. [XX] = 1-10 fans [10], 1-25 fans [25], 1-35 fans [35].
	DP-793	IDFC Controller	Easily mounts to field supplied electrical box for controlling each fan individually. Allows operation of the fans in either forward (cooling) or reverse (destratification). Manually control each fan's speed.
	DP-779	Single Yoke Controller	Includes Fwd/Off/Rev switch and 0-10 speed pot to control fan speed. NEMA 4x enclosure. (qty. 1) 100 Ft. wire factory supplied.. One per fan required.
	DP-783	Double Yoke Controller	Includes Fwd/Off/Rev switch and 0-10 speed pot to control fan speed. NEMA 4x enclosure. (qty 2) 100 Ft. wire factory supplied.. One per two fans required.
	DP-787	Triple Yoke Controller	Includes Fwd/Off/Rev switch and 0-10 speed pot to control fan speed. NEMA 4x enclosure. (qty 3) 100 Ft. wire factory supplied.. One per three fans required.
	BP-773-XX	Touch 'N' Go Premier Multi-Fan Controller	Operate 1-10 fans in forward/reverse with 0-100% speed control. Mounts to wall or electric gang box. Fully digital interface with password lockout capability. [XX] = 1 fan [01], 2 fans [02], 3-4 fans [04], 5-6 fans [06], 7-8 fans [08], 9-10 fans [10]
	BP-789	UltraLite Controller	Control each fan individually in the forward direction. Allows operation of the fan for cooling & destratification. Wire to be field supplied One per fan required.
	BP-775	VLD Controller	Control each fan individually via an economic digital interface. Wire to be field supplied.
<b>OPTIONAL ACCESSORIES</b>			
	BP-913	Purlin Mounting System	Mounting system for hanging SkyBlade Fans along purlin ceiling braces (hardware included).
	BP-901	230v Line Reactor	Cleans dirty voltage by reducing harmonic current and transient voltages. Includes one Nema 1 enclosure.
	BP-326	Single Yoke Control Cover	Add-on for the yoke controller to allow them to be padlocked. Includes two (2) shrouds (Lock not included).
	BP-915	I-Beam Adapter Kit	Required for installing to an I-Beam.
<b>LIMITED WARRANTY UPGRADES</b>			
	1061	Standard Level Warranty	Standard limited warranty 5 years-motor & reducer/1 year-electronic controls/lifetime-blades, chassis & hub.
	1062	Bronze Level Warranty	Upgrade warranty to 7 years-motor & reducer/3 years-electronic controls/lifetime-blades, chassis & hub.
	1063	Silver Level Warranty	Upgrade warranty to 10 years-motor & reducer/3 years-electronic controls/lifetime-blades, chassis & hub.
	1064	Gold Level Warranty	Upgrade warranty to 12 years-motor & reducer/7 years-electronic controls/lifetime-blades, chassis & hub.

**NOTE:** Refer to the Accessory List for detailed specifications and limitations on any of the above options.

# SHOP PROP SERIES WRITTEN SPECIFICATIONS

## HIGH VOLUME LOW SPEED FANS

- A. Basis-of-design product: Subject to compliance with requirements, provide WD Industries, dba SkyBlade Fan Company; **Shop Prop Series** high volume low speed ceiling fans.
- B. Complete Unit: The fan shall be designed to move an effective amount of air for cooling and Destratification in large industrial/commercial applications over an extended life. The fan and components shall be designed specifically for high volume, low speed fans to ensure lower noise operation. The sound levels from the fan operating at maximum speed shall not exceed <35 dBA (measured 20' or 6.1 m below the blades and 20' or 6.1 m horizontally from the center of the fan).
- C. Blades: The fan shall be equipped with five (5) high volume, low speed blades of precision 6005-T5 extruded anodized aluminum alloy. Each blade shall be of the high performance E420 (Short Take-Off and Landing) design. The blades shall be connected by means of two (2) locking bolts per blade. The blades shall be connected to "H-Strut" which is connected to the hub and interlocked with one set of five (5) steel retainers.
- D. Wingtips: The fan shall be equipped with five (5) wingtips designed to redirect outward airflow into downward airflow, thereby enhancing the efficiency and effectiveness of the fan. The wingtips shall be molded of Nylon 66. The wingtips shall be attached at the tip of each blade by means of a single screw. The standard color of the winglets shall be "SkyBlade Red," but may also be offered in black.
- E. Motor: The fan motor shall be an ECM (Electronically Commutated Motor), BLDC (Brushless DC), gearless direct drive 120-460 VAC, 1-3 Ph. The motor shall be totally enclosed with an IP65 NEMA classification. The motor shall be manufactured with Class F insulation. The output shaft of the motor shall have bearings that are lubed for life.
- F. Extension Bar: The fan shall be equipped with an extension bar that provides a structural connection between the fan assembly and upper mounting system. The extension bar shall be aluminum 2" x 2" (5.08 cm x 5.08 cm) square tubing and powder-coated for corrosion resistance and appearance. Standard length of extension bar is 6-1/2" available in additional 1-ft. increments up to 5-ft. as specified by the architect or owner.
- G. Hub: The fan hub shall be minimum 1/4" precision steel for high strength and rigidity. The hub shall be secured to the output shaft of the motor by means of a precision cut stainless steel cylinder & interlocking bushing system. Both hub and steel bushing shall be precision machined to achieve a factory balanced and solid rotating assembly. The hub shall incorporate six (6) safety retaining brackets no less than 1/8" made of stainless steel that shall restrain the hub/blade assembly in case of motor output shaft failure.
- H. Mounting System: The fan mounting system shall be designed for quick and secure installation from a structural support beam. All components in the mounting system shall be of welded construction using 1/4" powder-coated steel. All mounting bolts shall be Grade 5 or Grade 8 SAE.
- I. Guy Wire: The fan shall be equipped with a safety cable that provides an additional means of securing the fan assembly to the building structure. The safety cable shall be a four point restraint 1/8" (0.32 cm) diameter and fabricated out of 7 x 7 stranded galvanized steel with each cable having a breaking strength of 1,000 lbs. The cable is to be secured with supplied wire rope clips or fasteners. Field construction of safety cables is not permitted.
- J. Safety Cable: The fan shall be equipped with a safety cable that provides an additional means of securing the fan assembly to the building structure. The safety cable shall be 1/8" (0.32 cm) diameter and fabricated out of 7 x 7 stranded galvanized steel a break strength of 1,000 lbs. The cable is to be secured with supplied wire rope clips or fasteners. Field construction of safety cables is not permitted.
- K. VFD Enclosure: The fan controller shall be constructed using a Variable Frequency Drive (VFD) that is pre-assembled and factory programmed to communicate a 60 second ramp up/down to the fan, to minimize the starting and braking torques and for smooth and efficient operation. The VFD enclosure shall be pre-assembled and internally wired for ease of installation. The controller shall be onboard with IP65 rating.
- L. Warranty: The Manufacturer shall replace any products or components defective in material or workmanship, free of charge to the customer (including transportation charges within the USA, F.O.B. Warren, MI), pursuant to the complete terms and conditions of the SkyBlade Fan Company Non-Prorated Warranty in accordance to the following schedule:
- Blades - Lifetime (Parts)
  - Hub - Lifetime (Parts)
  - Motor - 5 years (Parts)\*
  - Controller - 1 years (Parts)\*
- \*If factory supplied installation methods are shown not to be valid, SkyBlade Fan Company has right to void warranty. Further Information on the terms and conditions of the standard & purchased warranties can be found in Warranty Card.
- SkyBlade is not liable for any voltage disturbances with explicit reference to electronic magnetic interference (EMI). Voltage disturbance refers to transient overvoltage, voltage unbalance, voltage swells, rapid voltage change, flicker, superimposed signals, harmonic voltages, supply voltage variations, voltage dips and frequency/time deviation.